

Seamless Handover in UMTS-HSDPA / WiMAX Interworking Using Proxy Mobile IPv6

Jacqueline. J. George, Mohammed Mohyeldin Siddig, Abdelrhman.O.A.Siribbal, Hind Al_jaily Mohammed, Rowa Mohammed Ishag, Wafa Hamid Abdelrhman

Abstract— providing an automatic handover for any moving device in a heterogeneous network with different access technologies is the main aim of Next Generation Networks. Using the global mobility protocol for managing localized mobility causes a number of problems, such as long registration delay, signalling overhead and location privacy. To overcome these problems, Proxy Mobile IPv6 is proposed which can avoid tunnelling overhead over the air and provide support for hosts without an involvement in the mobility management. In this paper, we present a UMTS-HSDPA and Mobile WiMAX interworking architecture based on the 3GPP and WiMAX standards and explain the seamless inter-system handover scheme using PMIPv6 which enables the service continuity with low handover latency.

Index Terms— Proxy mobile IPv6, UMTS-HSDPA, WiMAX, Interworking, Vertical handover, handover latency

1 INTRODUCTION

With the rapid growth in the number of mobile subscribers and mobile devices the demand for handover between networks is becoming an important concept in mobile telecommunication, beside the demand for “anywhere, anytime, and any way”, high-speed mobile services are becoming a primary concern in our lives [1].

Recent advances in various mobile wireless generations such as IEEE 802.16d/e and Universal Mobile Telecommunications System - High Speed Downlink Packet Access (UMTS-HSDPA) and worldwide interoperability for microwave access (WiMAX), and the incessant efforts of several standards bodies such as IETF, 3GPP, and ITU-T appear to increase the possibility of realizing mobile and ubiquitous computing environments [2]. However, many challenges still remain to be solved for achieving such a goal. The recent fundamental networking trend has focused mainly on combining the high data rate of WiMAX with the large coverage area and low cost of operation of UMTS-HSDPA in an architecture and allow the handover of mobile subscriber between them [3].

Over the last decade “mobility management” has become an important area of research and various new protocols and standards have been developed. Recently, the Proxy Mobile IPv6 (PMIPv6) [4], which is a network based mobility management protocol standard was ratified by the Network-based Localized Mobility Management (NetLMM) working group of IETF. PMIPv6 is a protocol that uses the same concepts as used in Mobile IPv6 (MIPv6), but modified to operate in the network part only instead of involving the Mobile Node (MN) as well. PMIPv6 is claimed to possess a number of advantages over the host based mobility management protocols in use today [5]. The main advantage of using PMIPv6 is the freeing up of the mobile host in doing any mobility related activities and thereby saving its resources.

This paper presents an inter-working architecture between two different access technologies capable of maintaining continuity of an on-going session without changing the IP address of the consumer while moving in an area covered by UMTS-HSDPA and WiMAX. The architecture presented has two

main features. Firstly, it uses a mobile device capable of maintaining identical radio links simultaneously with UMTS-HSDPA and WiMAX. The device is also capable to process, monitor and compare the signals received (RSS) through different interfaces and make decisions of handover when appropriate. Hence, the handover would be mobile initiated. The idea is that the user moves from one network to another when the coverage is not available or the network condition is not good enough. The second feature of this architecture is that it uses proxy mobile IPv6 at the network layer to provide network-based mobility management support to a mobile node (MN) in a topologically localized domain.

2 OVERVIEW OF PROXY MOBILE IPV6

PMIPv6 extends MIPv6 Signalling and reuses many concepts of MIPv6 such as the Home Agent (HA) functionality. PMIPv6 introduces two new network functional elements called Local Mobility Anchor (LMA) and Mobile Access Gateway (MAG). The LMA behaves like the HA of the MN in the PMIPv6 domain. It also has additional capabilities required for network-based mobility management [6].

Figure 1 and Figure 2 [6] shows the signaling call flow of the initial attachment and the handover procedure respectively.

As MN enters a PMIPv6 domain, it attaches to an access link. After the MAG receives router solicitation (RS) message from MN, it will perform the access authentication using MN's identity by sending a Query message to AAA server. After successful authentication, MAG gets the MN's profile and sends proxy binding update (PBU) message containing the identity of MN to LMA on behalf of the MN. Once LMA receives PBU, it performs the access authentication to insure that PBU is authorized. If both the MAG and MN are trusted, LMA accepts the PBU message, stores a binding cache for the MN and sends proxy binding acknowledgement (PBA) including the MN's home network prefix. MAG sends router advertisement (RA) messages to MN on the access link advertising the MN's home network prefix, which was given from LMA. Then

the MN configure the IP address, and uses the tunnel between MAG and LMA to send or receive packet. After the attachment procedure is completed, the MN's IP address remains the same while it moves within the PMIPv6 domain [6] [7].

the home link [7].

3 INTERWORKING ARCHITECTURE BETWEEN UMTS-HSDPA AND WIMAX NETWORKS

The interworking architecture between UMTS-HSDPA and WiMAX networks is shown in Figure 3. It is composed of several components:

- MN (Mobile Node): The mobile node that uses either UMTS or WiMAX network.
- BS (Base Stations): The stations of WiMAX network.
- Node B: The base station in UMTS-HSDPA network.
- RNC (Radio Network Controller): Controls node B's that are connected to it.
- AAA proxy server (Authentication, Authorization and Accounting unit).
- Two MAGs (Mobile Access Gateways), one is located with an ASN-GW (Access Server Network Gateway) in WiMAX network and the other with SGSN in UMTS-HSDPA network.
- LMA (Local Mobility Anchor) with two interfaces: One for UMTS network through the GGSN (GPRS Gateway Serving Network), and the other for WiMAX network through the Packet Data Gateway (PDG).
- PDN(Packet Data Network): it is a router to route the packets from one proxy domain to another [8].

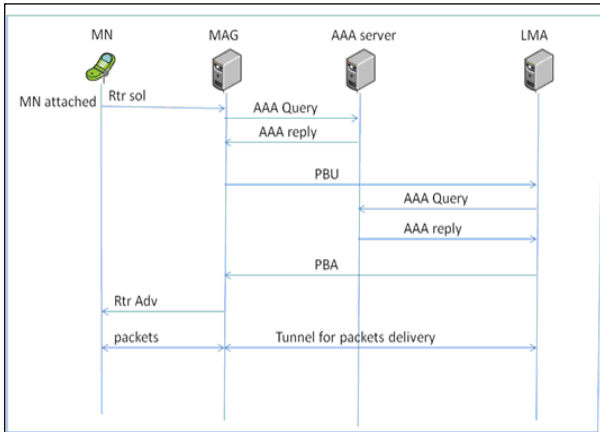

Fig.1. Signalling Call Flow of Mobile Node Attachment Procedure

When the MN moves to the access network of a new MAG, the old MAG detects that the MN has moved away from its

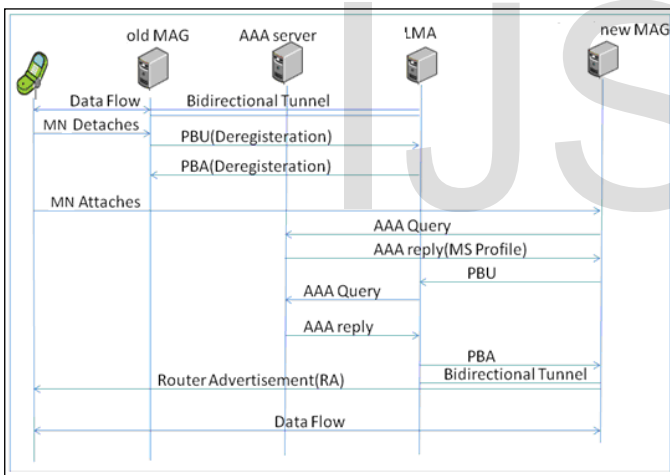

Fig.2. Signalling Call Flow of Mobile Node Handover Procedure

access link. Therefore, the old MAG sends a DeReg PBU (De-Registration PBU) message to the LMA for de-registration. Upon receiving the PBU message, the LMA sends a PBA message to old MAG and waits for an amount of time, before it deletes the MN's Binding Cache Entry [6] [7].

When the new MAG detects the attachment of MN, it obtains the MN-profile using an MN-ID after successful access authentication. The new MAG then sends a PBU message containing the identity of MN to the LMA in order to update the LMA about the current location of the MN. If that request is accepted the binding cache entry is updated with a new value which is the address of new MAG. After updating the binding cache entry, the LMA sends a PBA to new MAG, the new MAG then sends RA messages to the MN with its MN's IP. Upon receiving the RA message, the MN believes it is still on

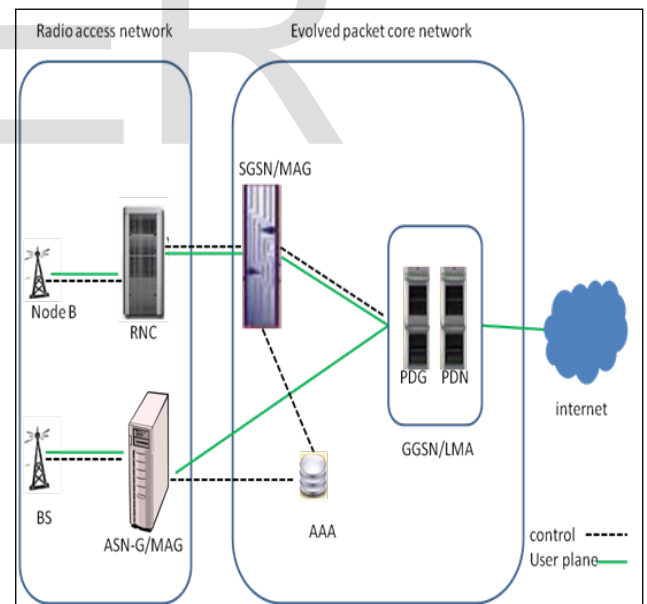

Fig.3. Architecture of Integrating Mobile Wimax within the UMTS-HSDPA Evolved Packet Network using PMIPv6

4 SYSTEM MODEL FOR PERFORMANCE EVALUATION

Handover latency is a critical factor in evaluating the handover performance of one protocol. In this section, by establishing the system model, we give the handover latency in the interworking architecture between UMTS-HSDPA and Wi-

4.1 System Model and Assumptions

Figure 4 shows the system model used to evaluate the handover latency in the interworking architecture between UMTS-HSDPA and WiMAX networks when using PMIPv6. In this simulation, it is assumed that the UMTS-HSDPA has a radius of 2.4 km with a bandwidth of 7.2 Mbps and that the range of each WiMAX BS (base station) is 1 km in radius with a bandwidth of 70 Mbps. It is also assumed that the system is designed to receive and transmit 1000 packets per second with size of 1000 bytes and a delay of 0.01 msec between packets. The link bandwidth between LMA, MAGs, and AAA server is fixed to 100 Mbps [8][9]. The path-loss and shadowing used to calculate the RSS of MN is mathematically given by Eq.1:

$$RSS = PL(d_0) - 10 \log(d/d_0) + \sigma \quad (1)$$

Where:

- PL (d₀) = the received power at a reference distance (d₀).
- d = the distance between base station and MN.
- σ = the zero-mean Gaussian random variable.
- d₀ = is the reference distance, usually 1 km.

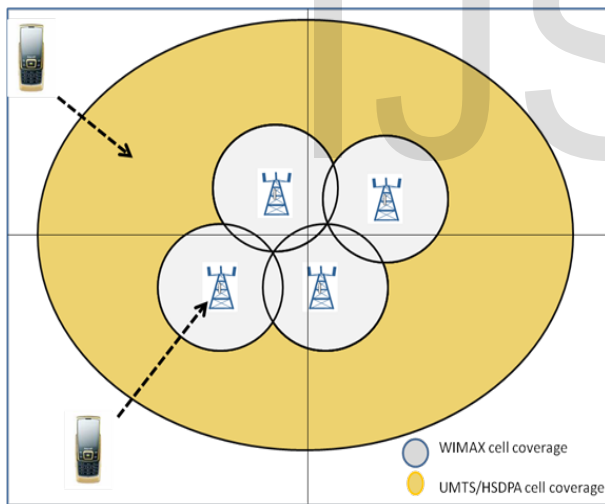

Fig.4. System Model

4.2 Handover Latency Analysis

A simple analytical model shown in Figure 5 was considered for the performance analysis. The notations in Figure 5 are defined as follows:-

$$T_{wimax} = \frac{Packets\ size}{WiMAX\ Bandwidth} \quad (2)$$

T_{wimax}: is the packet transmission delay between Wimax BS and MN and is given by Eq.2

T_{umts}: is the packet transmission delay between UMTS-HSDPA nodeB and MN and is given by Eq.3:

$$T_{umts} = \frac{Packets\ size}{UMTS / HSDPA\ Bandwidth} \quad (3)$$

T_{link}: The delay in wired link between AAA, MAG and LMA and is given by Eq.4

T_{packet} : is the packet transmission delay and is given by:

$$T_{link} = \frac{Packets\ size}{Link\ Bandwidth} \quad (4)$$

$$T_{packet} = No\ of\ packets \times delay\ between\ packets$$

T_{process}: the delay of packets process in each one of the three main units AAA, MAG and LMA which is considered the same for all.

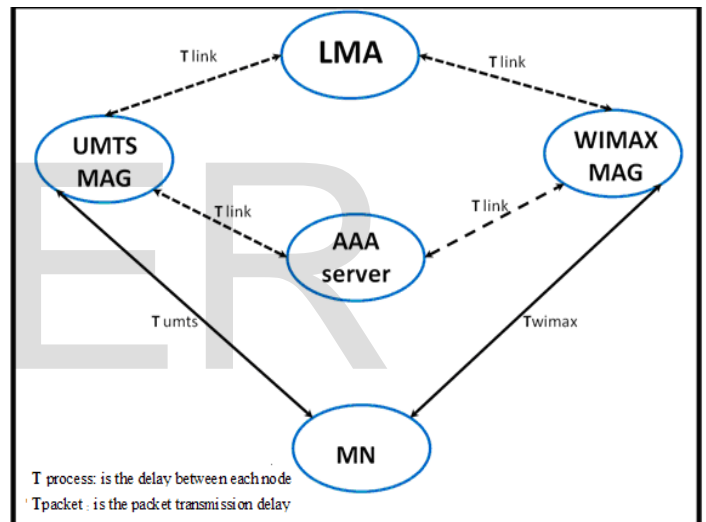

Fig.5. Handover Latencies

The IP handover latency can be expressed as the sum of the above latencies, more specifically, handover latency is defined as the time that elapses between the moment the layer 2 handover completes and the moment the MN can receive the first data packet after moving to the new point of attachment. In order to estimate the total handover delay, based on the assumptions mentioned, the handover operation from one network to another is expressed as follow:

MN delay over UMTS network is:

$$UMTS\ delay = T_{umts} + T_{packet} + T_{link}$$

Handover signalling delay:

$$Signalling\ delay = 2 * T_{process} + T_{link}$$

Packets buffering delay time in LMA:

$$Buffering\ delay = T_{process} + 3 * T_{link}$$

MN delay over the WiMAX wireless link:

$$WiMAX\ delay = T_{wimax} + T_{packet} + T_{link}$$

5 SIMULATION ANALYSIS

In order to evaluate the handover latency in the interworking architecture between UMTS-HSDPA and WiMAX networks when using PMIPv6, two cases were considered. Figure.6. shows the first case, where the MN is first attached to the UMTS-HSDPA network and then a handover to the WiMAX Network occurs. The MN first sends a request to the UMTS-HSDPA network for attachment. The mobility signaling is then done between the SGSN/MAG and GGSN/LMA on behalf of the MN, after that the LMA establishes a tunneling channel with the SGSN/MAG and the MN start transmitting its packets using the UMTS-HSDPA network link. The RSS signal is then measured each second, until the MN enters the overlapping area and the RSS becomes lower than the threshold value, then the handover signalling procedure starts. After successful handover the MN start transmitting its packets using the WiMAX network link.

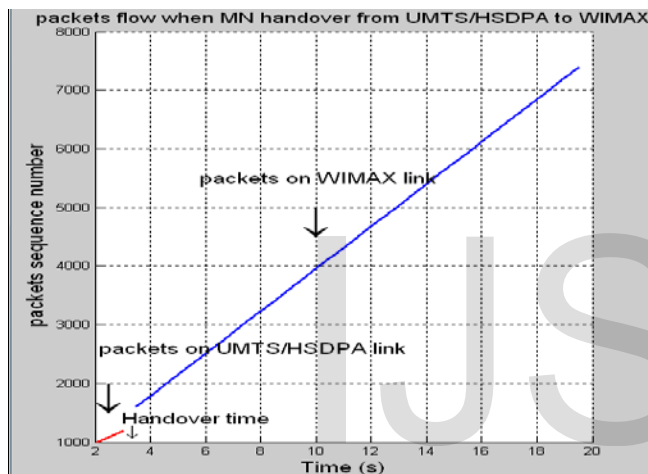

Fig.6. Packets Flow when MN Handover from UMTS/HSDPA to WiMAX

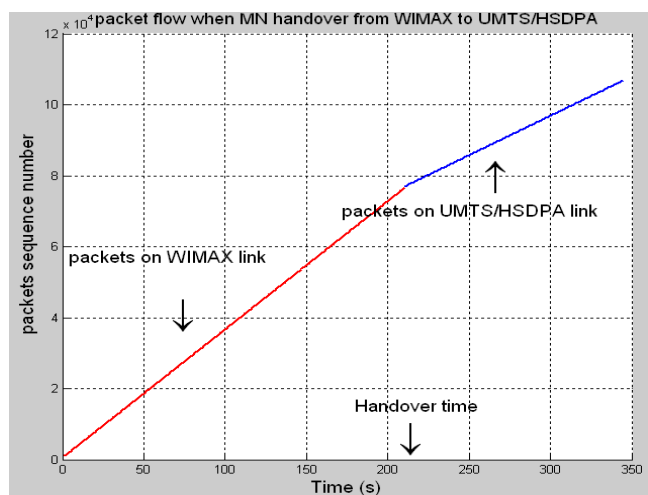

Fig.7. Packets flow when MN Handover from WiMAX to UMTS/HSDPA

Figure.7. shows the second case with the handover reversed between the two networks; the MN is now attached to the WiMAX network. The mobility signaling is done between the ASN-G/MAG and GGSN/LMA on behalf of the MN then a

tunneling channel is established where the MN start transmitting its packets using the WiMAX network link. The MN then enters the overlapping area and the handover signaling procedure starts. After successful handover the MN start transmitting its packets using the UMTS-HSDPA network link.

As can be observed from Figure.6 and Figure.7, the signal gets disconnected from the MN around 0.44 sec in case of UMTS-HSDPA to WiMAX handover and 0.1257 sec in case of WiMAX to UMTS-HSDPA handover, resulting in packets buffered in LMA as the MN enters the overlap area (i.e., leaves the old network for the new network). The discontinuity corresponds to the period when handover procedures are performed, and the MN is unable to send or receive ongoing communication. It can also be observed that the delay when transmitting the packets in UMTS-HSDPA is greater than that of the WIMAX due to the narrow bandwidth of UMTS-HSDPA and the large bandwidth of WIMAX.

6 CONCLUSION

The objective of this paper was to implement a new mechanism of vertical handover between UMTS-HSDPA and WiMAX networks; therefore, a new interworking architecture was proposed by using PMIPv6 as the mobility management protocol over the two networks.

The UMTS-HSDPA network was considered as the 3G network technology due to its large coverage area and quality of service compared with the old series of 3G network technologies. The WIMAX is one of the 4G networks technologies, which provide high data rate up to 75 Mbps.

Due to the large coverage area and high data rate that the UMTS-HSDPA and WIMAX provide, the two networks were chosen to provide better solution for the rapid growth of demand for "anywhere, anytime high-speed Internet access, with respect of decreasing the cost of installation new networks infrastructure of the 4G system.

In this paper the handover latency in the interworking architecture between UMTS-HSDPA and WiMAX networks using PMIPv6 was simulated. The simulation showed that the PMIPv6 performs well and obtained a reasonable handover delay, the results also showed that the delay obtained when transmitting the packets in UMTS-HSDPA is greater than that of the WIMAX due to the narrow bandwidth of UMTS-HSDPA and the large bandwidth of WIMAX

REFERENCES

- [1] P. Vidales, J. Baliosian, J. Serrat, and G. Mapp, "Autonomic system for mobility support in 4G networks", *IEEE Journal on Selected Areas in Communications*, vol. 23, no. 12, pp. 2288-2304, 2005
- [2] H. Fathi, R. Prasad, and S. Chakraborty, "Mobility management for VoIP in 3G Systems: Evaluation of Low-latency Handoff Schemes", *IEEE Wireless Communications*, vol. 12, no. 2, pp. 96-104, 2005.
- [3] R. Koodli et al., "Fast Handovers for Mobile IPv6", RFC 4068, IETF, July 2005
- [4] S. Gundavelli et al., "Proxy Mobile IPv6", RFC 5213, IETF, August, 2008.
- [5] K. Kong, W. Lee, Y. Han, M. Shin, and H. You, "Mobility management for all-IP mobile networks: mobile IPv6 vs. proxy mobile IPv6",

IEEE Wireless Communications, vol. 15, no. 2, pp. 36-45, 2008.

- [6] Yong Li, Haibo Su Li, Su Depeng Jin and Lieguang Zeng, "A Comprehensive Performance Evaluation of PMIPv6 over IP-Based Cellular Networks", *69th IEEE Vehicular Technology Conference*, 2009.
- [7] Ju-Eun Kang¹, Dong-Won Kum², Yang Li², and You-Ze Cho², "Seamless Handover Scheme for Proxy Mobile IPv6", *IEEE International Conference on Wireless & Mobile Computing, Networking & Communication*, 2008
- [8] Thazin Ei and Wang furong "Trajectory-Aware vertical Handover protocol Between WiMAX and 3GPP networks", *Information Technology Journal*, 9: 201-214, 2010.
- [9] Doufexi, E. Tameh, A. Nix, S. Armour and A. Molina, "Hotspot wireless LANs to Enhance the Performance of 3G and Beyond Cellular Networks", *IEEE Communication Magazine*, Vol. 41, pp. 58 - 65, July 2003.

IJSER